

Description

Chinasound Piezo Transducer 12.7(<13mm) diameter, type E(=6.8mm height), 12Vp-p rated voltage – 4.0KHz resonant frequency, RoHS compliant

- ◆ RoHS compliant
- ◆ Reliable Solid State Piezoelectric Technology
- ◆ Corrosion Resistance Diaphragm
- ◆ Flame Retardant Plastic

Picture



Frequency Response Curve

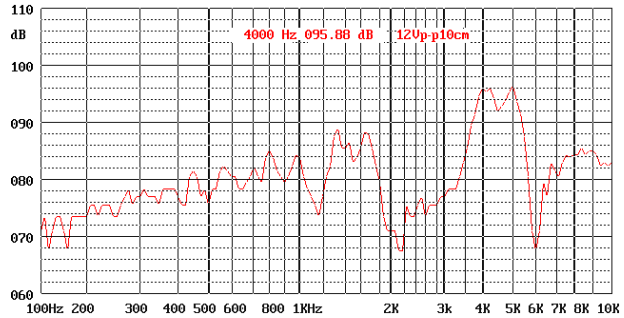

Specification

- Rated Voltage
- Operating Voltage
- Operating Frequency
- Typical Sound Output
- Typical Operating Current
- Capacitance
- Operating Temperature
- Storage Temperature
- Termination
- Construction Materials
- Weight (Typical)
- Reliability

**Description
Case
Diaphragm**

- *Life Test
- *High Temperature
- *Low Temperature
- *Humidity
- *Thermal Shock

***Vibration**

***Shock**

***Drop Test**

***Soldering Heat Resistance**

****Solderability**

12 Vp-p, square wave
 3 - 30 Vp-p, square wave
 4,000+/-500Hz
 88dB min. at 12Vp-p 10cm 4KHz 25 °C
 4mA at 12Vp-p
 10,000+/-30% pF at 100Hz 1Vrms
 -40 °C to +85 °C
 -40 °C to +90 °C
 2 soldering pins, Sn plated Brass
 Plastic, Noryl PX9406
 Brass Disc
 1.4 g
 At 12 Vp-p, 1 minutes ON 1 minutes OFF in room temperature continuously for 1000 hours
 No function at +90+/-2 °C for 240 hours; Function at +85+/-2 °C for 240 hours
 No function at -40+/-2 °C for 240 hours; Function at -40+/-2 °C for 240 hours
 +40+/-2 °C, 95+/-5%RH, 240 hours
 -40+/-2 °C 0.5 hr → +25+/-2 °C 0.25 hr → +85+/-2 °C 0.5 hr → +25+/-2 °C 0.25 hr.
 Temperature Go up or Drop time is 0.5 hr. 3 hrs per 1 cycle. Total is 5 cycles
 1.5mm with 10 to 50Hz of vibration frequency to each of 3 perpendicular directions for 2 hours
 980m/s² (=100g) shock for each mutually perpendicular directions, half sine wave, 3 times each
 Dropped naturally from 750mm height onto the surface of 10mm wooden board. 2 directions – upper and side of the part are applied
 Pins are immersed up to 1.5mm from sounder's body in solder bath of 350+/-5 °C for 3+/-0.5 seconds
 Lead terminals are immersed in rosin for 5 seconds and then immersed in solder bath of 350+/-5 °C for 3+/-0.5 seconds.

Warranty

*All specifications must be satisfied after the test (Recovery:2 to 4 hrs of recovery under the standard condition after the removal from test chamber).
 **90% min. soldering pads shall be with solder.(except the edge of pad)

Dimensions (Unit:mm, Tolerance: +/-0.3mm)

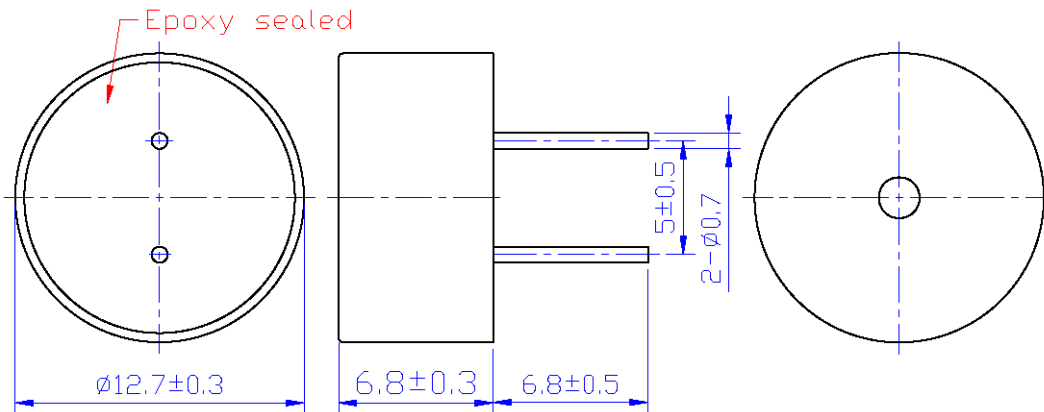

All specifications are subject to change without notice

Composed by: Guo Jun/080111 Checked by: Gao CL, Gong YS, Zhu YC/080111 Approved by: Wang Z/080111



CHANGZHOU CHINASOUND ELECTRONICS CO., LTD.

Tel: +86-519-86182518 Fax: 86182519

http://www.chinasound.com

email: csound@jsmail.com.cn

Revisions History

Version Number	Description	Name
080111	Original, CPT13E12-4.0R	Guo Jun

Composed by: Guo Jun/080111 Checked by: Gao CL, Gong YS, Zhu YC/080111 Approved by: Wang Z/080111

ChinaSound

CHANGZHOU CHINASOUND ELECTRONICS CO., LTD.

Tel: +86-519-86182518 Fax: 86182519

<http://www.chinasound.com>
email: csound@jmail.com.cn