

Description

CMS40R5-8N0.2-1T500R:

Chinasound Micro Speaker 40mm diameter, Round metal frame, 5mm height - 8 ohm rated impedance, NdFeB magnet, 0.2W rated power – type 1, Transparent Mylar cone, 500 Hz rated frequency, RoHS compliant

- ◆ RoHS complaint
- ◆ Water-proof
- ◆ Small size

Picture



Frequency Response Curve Tested by LMS at 0.2W 0.5m

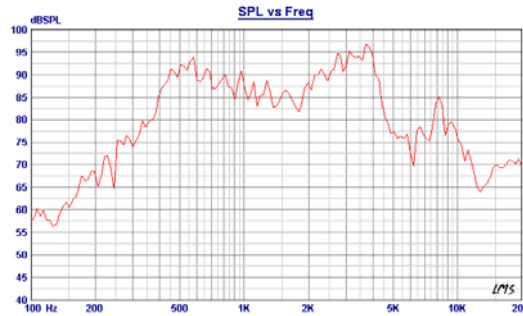

Specification

Rated Impedance		8+/-15% ohm (Other Rated Impedance is available.)
Rated Power		0.2 W
Max. Power		0.4 W
Resonant Frequency		500+/-20% Hz
Frequency Range		fo ~ 450 Hz
Sound Pressure Level		85/-3 dB 1W1m (Average of SPL values at 800, 1000, 1200 & 1500 Hz.)
Operating Temperature		-20°C to +60°C
Storage Temperature		-30°C to +70°C
Termination	Description	PCB
Construction Materials	Case	ABS 757
	Diaphragm	Transparent Mylar
Weight (Typical)		
Reliability	*Buzzes & Rattles	Must be normal at 1.26V(=0.2W) sine wave
	*Load Test	0.2W white noise for 96hrs
	*High Temperature	no function at +70 +/-2°C for 96 hours, function at +60+/-2°C for 16 hours,
	*Low Temperature	no function at -30+/-2°C for 96 hours, function at -20+/-2°C for 16 hours,
	*Humidity	+40+/-2°C°, 90 ~ 95% R.H. for 48hrs
	*Thermal Shock	-20+/-2°C, 30min→+20°C,15min,→+60+/-2°C, 30min→+20°C,15min, 5 cycles
	*Vibration	1.5mm with 10 to 50Hz of vibration frequency to each of 3 perpendicular direction for 2 hrs
Warranty		For a period of one (1) year from date of manufacture under normal operations

* All specifications must be satisfied after the test (Recovery:2 to 4 hrs of recovery under the standard condition after the removal from test chamber).

Dimensions (Unit: mm)

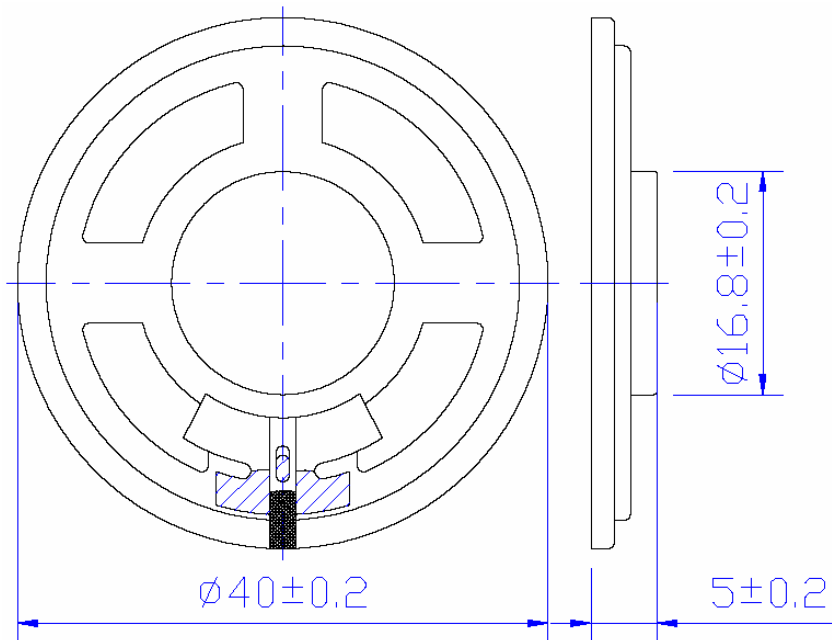

All specifications are subject to change without notice